

Inquiry form – drum drive wheels / drum load wheels

Please email to: rv@raedervogel.de

or fax: +49 40 75499-175

Please send me an offer for:

Drum drive wheel ____ piece/s Drum load wheel ____ piece/s

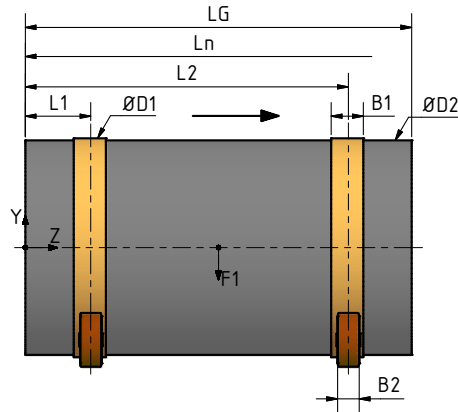
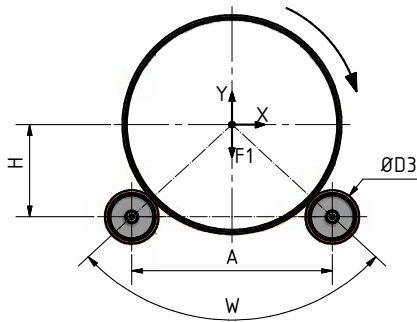

Dimensions/Wheel material *Please fill out if known!

Wheel material _____

*Overall length (LG) _____ (mm) *Distance contact surface 1 (L1) _____ (mm)

*Distance contact surface 2 (L2) _____ (mm) *Distance contact surface 3 to n (Ln) _____ (mm)

*Diameter contact surface (D1) _____ (mm) *Drum diameter (D2) _____ (mm)

*Wheel diameter (D3) _____ (mm)

*Contact surface width (B1) _____ (mm) *Wheel width (B2) _____ (mm)

*Centre-to-centre distance / angle (A/W) _____ (mm/°) *Height of axes / angle (H/W) _____ (mm/°)

*Drum weight (F1) _____ (N) Weight of medium (F2) _____ (N)

*Total weight (F3) _____ (N)

Required date _____

Conditions /other _____
(speed, revolution,
temperature etc.) _____

Customer number _____
(if present)

*Company name _____

*Last name _____ First name _____

*Address _____ *House number _____

*Postal code, city _____ *Country _____

*Phone No. _____ *Fax _____

*Email _____ Homepage _____

If available, please add a drawing or sketch to the inquiry.